

HI-PE

High Performance Walk-Through Multi-Zone Metal Detector



**NEW
GENERATION**

- Accurate Detection of magnetic, non-magnetic and mixed-alloy metal weapons
- High Discrimination and Throughput
- Exceptional Immunity to external interferences
- Unmatched Reliability
- Rapid Installation

HI-PE

High Performance Multi-Zone Metal Detector



Accurate Detection



VERY HIGH SENSITIVITY

- Capable of detecting a wide range of threat objects composed of magnetic, non-magnetic metals and mixed alloys



HIGH RESOLUTION AND PRECISION

- Quick, accurate analysis of all parts of the body of people in transit, from the shoe level to the crossbar

The HI-PE is a high performance walk-through Multi-Zone Metal Detector which meets all International Security Standards. A "height on person" display actually indicates, by means of illuminated LED's, the position of the weapon on the person.

The HI-PE allows a high level of discrimination between significant metal masses, such as the weapons which are to be detected, and personal metal items.

Exceptional immunity to external interference makes it easy to use even when electrical noise is encountered. The detection capability is independent of the transit speed.

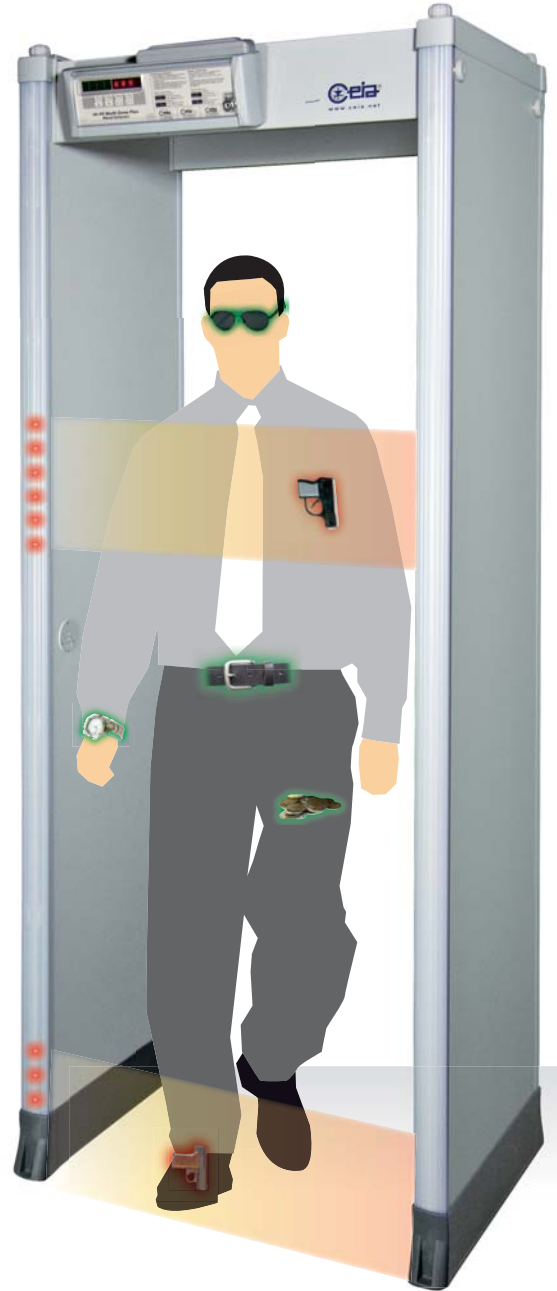

Breakthrough Value



UNMATCHED RELIABILITY

- Superior CEIA reliability slashes total cost of ownership

The overall system is characterized by sturdy, reliable electronic and mechanical construction, and ease of installation.



MAINTENANCE FREE

- No periodic re-calibration and preventive maintenance required

Communication Capabilities

TYPE OF OPERATION	Ethernet	USB	Infrared	RS-232
Maintenance	○	○		●
Remote Control	○		●	●
Remote Data collection	○			

● STANDARD ○ OPTION

HI-PE

High Performance Multi-Zone Metal Detector

Model Configuration

Features	HI-PE/PZ
2 display bars programmable as zone indicators and/or pacing lights	●
Dual Side 20 localization zones	●
Powered by safe low voltage DC	●
RS-232 communication	●
Password and hardware key access protection	●
Anti-tamper on/off switch	●
Weather resistant protection	○
Anti-vandalism, anti-tampering protection	○
IP65 protection (includes weather resistant and anti-vandalism options)	○
High precision transit counter	○
Programmable Random Alarm capability*	○
embedded battery back-up and charger	○
Integrated web-server & logger (includes Ethernet and USB interface)	○
Long life crossbar battery back-up	○
820 mm useful passage width	○

● STANDARD ○ OPTION *Transit Counter required

Dimensions

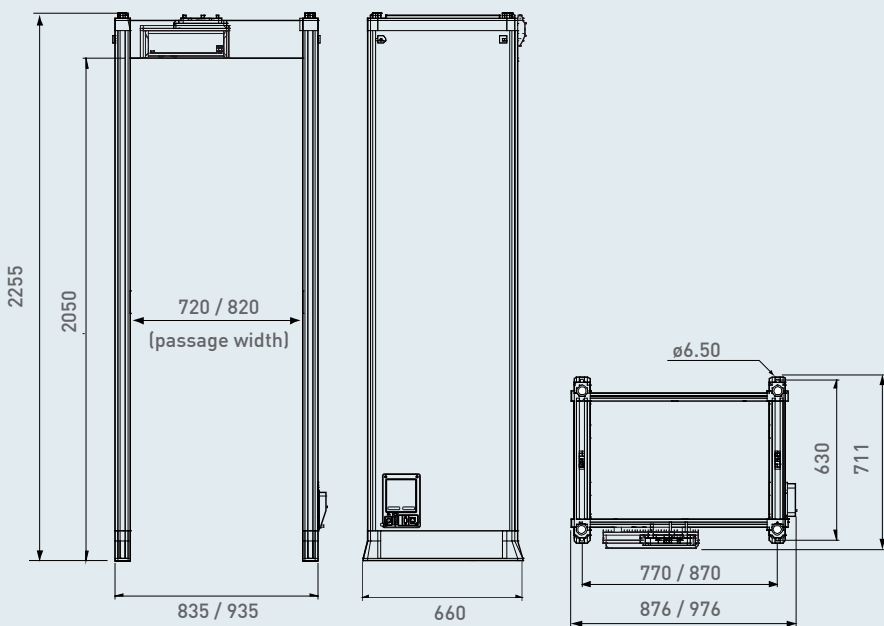

Exceptional Immunity



CEIA HI-PE METAL DETECTORS OFFER SUCH HIGH IMMUNITY THAT THEY CAN BE INSTALLED EVEN IN ENVIRONMENTS WITH HIGH LEVELS OF ELECTRICAL INTERFERENCE, IMPOSSIBLE FOR CONVENTIONAL METAL DETECTORS

Visual alarm zone indication

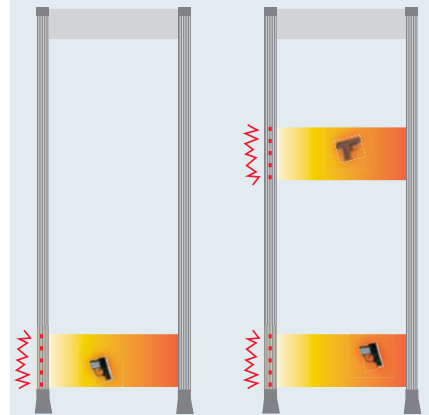

SINGLE & MULTIPLE LOCATION OF THE METAL MASS DETECTED

UNDER THE ALARM THRESHOLD

- Small metal mass
- Medium metal mass

OVER THE ALARM THRESHOLD

- Medium metal mass
- Large metal mass

GREEN AND RED METERING SIGNALS PROPORTIONAL TO THE METAL MASS DETECTED



Options and Upgrade Kits

WEATHER RESISTANT PROTECTION

Kit for upgrading the standard version to outdoor applications according to IEC 60950-22; this kit includes shelters, crossbars and protection covers for power supply.

Part # 55630



ANTI-VANDALISM, ANTI-TAMPERING PROTECTION

This option includes stainless steel control unit, protection covers for power supply and antenna connection compartments. Equipped with screws requiring tools for removal.

Part # 55629



IP65 PROTECTION

This option includes the Weather Resistant and Anti-vandalism kits.

Part # 55631

LONG LIFE CROSSBAR BATTERY BACK-UP

Crossbar battery back-up in stainless steel case. Provides up to 17.5 hours of autonomous working time.

Part # 55681

17.5 HOURS TYPICAL (10 HOURS MINIMUM) CONTINUOUS OPERATION WITH HI-PE



820 mm USEFUL PASSAGE WIDTH

Part # 55635

EMBEDDED BATTERY BACK-UP AND CHARGER

Anti-tamper on/off switch, RS-232 interface, 65 minutes typical (50 minutes minimum) internal battery back-up with 12 hours mains disconnection diagnostic alarm.

Part # APSM2Plus/P



INTEGRATED WEB-SERVER & LOGGER, BATTERY BACK-UP AND CHARGER

Anti-tamper on/off switch, RS-232, USB, 10/100 baseT Ethernet interface, data logger, real-time clock, integrated web-server, transit statistical data analysis, 20' internal battery back-up with 12 hours mains disconnection diagnostic alarm.

Part # APSiM2Plus/P



HIGH PRECISION TRANSIT COUNTER

Two photocells fitted into the archway allow counting of transits, alarms and percentage of alarms.

Part # 32716



Accessories

➤ MBSU-2

Independent, long life power supply in weatherproof stainless steel case, with embedded fast charger:

- 32 hours typical (18.5 hours minimum) continuous operation with HI-PE
- 5 hours typical charging time.

Part # MBSU-2



➤ IRC-1

Infrared Remote Controller for wireless remote programming of the control unit.

Part # 47180



➤ UPPER CONNECTION MODULE

This extension cable allows the connection of power supply and serial communication to personal computers or CEIA accessories, such as RCU-2.

Part # 46650

➤ RRU

Remote relay unit (RRU) to repeat the detection alarms of the gate through a relay contact. The RRU module can be used for integration of the Metal Detector in interlocked door systems.

Part # RRU

➤ WATERPROOF MAINS POWER SUPPLY

100W IP67 power supply for outdoor applications. It is provided with flanges for simple installation.

Part # 43564



➤ RCU2

Control unit for full remote access, including alarm signaling and programming of CEIA Walk Through Metal Detectors.

Part # RCU2



VISUAL ALARM WITH ZONE INDICATION

➤ MD-SCOPE

Powerful, PC based installation and service Software. Includes oscilloscope and terminal functionality.

Part # MD-SCOPE2



➤ METAL DETECTOR DIVESTING TABLE FOR MANAGEMENT OF PERSONAL METAL BELONGINGS

- Standard length: 610 mm (Part # 18074)
- Extended length: 1200 mm (Part # 39491)



➤ TEST SAMPLES KIT

Reference Samples for accurate verification of the Security Level. Includes guided procedures and certificate of calibration.

Part # 3497 (NILECJ-STD-0601.00 Level 2)

Part # EMD-SK-GAL (GA test pieces)



HI-PE

High Performance Multi-Zone Metal Detector



Specifications

KEY FEATURES	Accurate Detection of magnetic, non-magnetic and mixed-alloy metal weapons	
	Wide range of threat detection from guns to 1/2 cutter blade	
	High Discrimination and Throughput	
	Exceptional Immunity to external interferences	
	High precision bidirectional counter with automatic rescreening compensation (option)	
	Random alarm capability programmable from 0% to 100% (option)	
	Powered by safe low voltage DC	
	Standard Interfaces: RS-232, Infrared	
QUALITY	Other available interfaces: Ethernet, USB	
	Continuous self diagnostic system	
	Proven reliability	
	No periodic re-calibration and preventive maintenance required	
	No scheduled maintenance	
WALK-THROUGH GATE STRUCTURE	Fully digital design	
	State-of-the-art, robust and washable panels	
CENTRAL CONTROL UNIT	Protected against aging, weather and wear	
	Ergonomic and robust design	
	High visibility alphanumeric display and programming keyboard	
ALARM SIGNALLING	Made of advanced plastics or stainless steel and anti-vandalism construction (option)	
	Access to the front panel protected by hardware key and two levels of passwords	
	VISUAL SIGNALS	Multi-zone display bar for "height on person" localization 2 light bars with selectable entry/exit and pacing indication Green and red metering signals proportional to the mass of the detected target
TYPE OF SIGNALLING	AUDIO SIGNALS	10 selectable continuous and pulsed tones 10 selectable sound intensities ranging from 0 to 90 dbA at 1m
	VISUAL ZONE INDICATION	Fixed or proportional to the mass in transit - visible from 6m under lighting of 4000lux. 2, 4, 8 or 20 independent zones selectable
PROGRAMMING	Remote via RS-232, Infrared Remote Control Unit or Ethernet 10/100 base T interface	
	SECURITY LEVEL	International Standard (IS) command
	Local by Control Unit alphanumeric display and keyboard Programming access protected by user and super-user passwords	
OPERATIONAL FEATURES	Quick reset time as short as 0.2 seconds for high throughput rate	
	Very high detection speed (up to 50 ft/sec.)	
	One-touch key reading of inbound, outbound and Security Level Data	
INSTALLATION DATA	Automatic synchronisation between two or more metal detectors with distance of down to 5 cm without the use of external cables	

Environmental Data

- **POWER SUPPLY** : 100...240V~ -10/+15%, 47...63Hz, 25 VA max
- **OPERATING TEMPERATURE**: -20°C to +70°C
- **STORAGE TEMPERATURE**: -35°C to +70°C
- **RELATIVE HUMIDITY**: 0 to 95% (without condensation)

Certification and Compliance

- Compliant with the applicable Standards for Walk-Through Metal Detectors
- Compliant with the applicable electromagnetic Standards on Human Exposure and Pacemaker Safety
- Compliant with applicable International Standards for electrical safety and EMC
- Harmless to magnetic media (floppy disks, tapes, etc.)

Comprehensive support

CEIA PROVIDES FULL OPERATIONAL AND TECHNICAL TRAINING SUPPORT BY CERTIFIED PERSONNEL EITHER AT CEIA FACILITY OR AT CUSTOMER PREMISES



- phone technical support
- in-house and on-site repair/ services
- standard and custom training



Zona Industriale 54/G, 52041 Vicinaggio - Arezzo (ITALY)
Tel.: +39 0575 4181 Fax: +39 0575 418298 E-mail: infosecurity@ceia-spa.com

www.ceia.net

CEIA reserves the right to make changes, at any moment and without notice, to the models (including programming), their accessories and options, to the prices and conditions of sale

DP060K0048V1UK-